

COMMENTARY TO AG:PT/T105 - PRE-TREATMENT OF POLYMER MODIFIED BINDERS (THERMAL STABILITY TEST)

PREFACE

This test method was prepared by Queensland Department of Main Roads and has been adopted by Austroads. Representatives of Austroads, ARRB Group and the Australian Asphalt Pavement Association have been involved in the development and review of this test method.

FOREWORD

Polymer modified binders (PMBs) can undergo significant changes to their properties when exposed to high temperatures for extended periods of time. This laboratory pre-treatment simulates the conditions likely to be encountered during storage and transportation of PMBs and is intended as a precursor to an appropriate characterisation test.

SCOPE

This test method sets out the procedures for rolling thin film oven (RTFO) pre-treatment of a wide range of binders and the determination of the loss on heating of asphalt grade binders including bitumens, polymer modified binders and multigrade binders. The method provides a pre-treatment for binders which are to be tested in accordance with the test methods set out by Austroads for asphalt grade binders.

Further Development

There are no further plans for the development of this test method.

PRE-TREATMENT OF POLYMER MODIFIED BINDERS (THERMAL STABILITY TEST)

1 REFERENCED DOCUMENTS

The following documents are referred to in this method:

AUSTROADS

AG:PT/T101 Method of sampling polymer modified binders, polymers and crumb rubber

AG:PT/T102 Protocol for handling polymer modified binders in the laboratory

AS /NZS

2008 Residual bitumen for pavements, Appendix B - Sampling

2341.10 Determination of the effect of heat and air on a moving film of bitumen(rolling thin film oven (RTFO) test)

2341.13 Long-term exposure to heat and air

3 APPARATUS

The following apparatus is required in addition to that listed in AS/NZS 2341.10 and AS/NZS 2341.13

- a) Balance - a suitable balance of 1 kg capacity, readable to 0.01 g.

4 PROCEDURE

4.1 General

PMBs are complex mixtures of polymers and a variety of petroleum products. If handled in accordance with the directions of the suppliers, there should be no significant risk. The hazard of burns with PMBs is greater than with standard bitumens, due to the (normally) higher handling temperatures. It is recommended that notices, describing the action to be taken in the event of bitumen or PMB burns, should be displayed in the laboratory in the areas where bitumen and PMBs are handled. A suitable warning could be as follows:

WARNING: HOT BITUMEN & PMBs CAN CAUSE BURNS

The following precautions should be taken when handling bitumen, or PMBs:

- a. Eye protection, such as safety glasses and/or face shields, shall be worn when handling hot bitumen or PMBs.
- b. Heat-resistant gloves, with close-fitting cuffs, and other suitable protective clothing, shall be worn when handling hot bitumen or PMBs.

- c. There shall be no smoking while handling hot bitumen or PMBs.
- d. While the material is still cold, loosen the lid of the sample container (invert the can and warm the lid, if necessary), or punch a hole in the lid.
- e. Examine the cold sample for the presence of water. If water is thought to be present, drain most of it out, or blow with clean compressed air to evaporate the free water.

4.2 Sample preparation

PMB samples for testing shall be provided in accordance with AG:PT/T101 and AG:PT/T102. Bitumen and multigrade samples shall be provided in accordance with AS2008, Appendix B: SAMPLING. It is recommended that all binders be handled in the laboratory in accordance with AG:PT/T102 where the requirements are more rigorous.

4.3 RTFO treatment

The appropriate procedure shall be followed as a precursor to the determination of asphalt grade binder characteristics. Appendix A describes two developments of the standard procedure. A1 uses the standard glass treatment bottle and is a refinement of AS2341.10. This version calibrates the oven temperature to an “in-bottle” temperature. Procedure A2 is a further development of method A1 and uses a larger quantity of binder and a metal treatment bottle with an internal roller to assist the flow of the binder through the treatment.

4.4 Loss on Heating

The procedure for determination of Loss on Heating shall be as follows:

- a) Pre-treated sample mass
 - (i) Weigh a clean RTFO bottle to the nearest 0.01 g and record the mass, M_1 .
 - (ii) Add the required quantity of binder, as specified in Appendix A or AS/NZS 2341.10, to the RTFO bottles.
 - (iii) Weigh the RTFO bottle containing the binder to the nearest 0.01 g and record the mass, M_2 .
- b) Pre-treatment

Follow the procedure for the appropriate RTFO test, as described in Appendix A or AS/NZS 2341.10.
- c) Treated sample mass

Cool the RTFO bottle to room temperature and weigh to the nearest 0.01 g. Record the mass, M_3 .

5 CALCULATION

Calculate the loss on heating using the following formula:

- a) Sample not retained for further testing

$$\text{Loss on heating (\% mass)} = \frac{100 \times (M_2 - M_3)}{(M_2 - M_1)}$$

Where

M_1 mass of RTFO bottle (g)

M_2 mass of RTFO bottle and untreated sample (g)

M_3 mass of RTFO bottle and treated sample (g)

- b) Treated sample to be required for additional testing (see Note 1)

$$\text{Loss on heating (\% mass)} = \frac{100 \times [(M_5 - M_1) + (M_6 - M_4)]}{(M_2 - M_1)}$$

Where

M_1 mass of RTFO bottle (g)

M_2 mass of RTFO bottle and untreated sample (g)

M_4 mass of test container (g)

M_5 mass of RTFO bottle and residual treated sample (g)

M_6 mass of test container and treated sample (g)

5 REPORT

The following information shall be reported:

- a) A comment (see Note 3) on the sample behaviour during the test, in terms of its flow characteristics.
- b) The loss on heating, as a percentage mass to the nearest 0.1%.

6 PRECISION

No inter-laboratory testing has been conducted for the range of bitumens and multigrade binders currently available. The following precision estimate has been derived from the 1998 Austroads inter-laboratory precision exercise for PMBs.

- a) **Repeatability:** Duplicate mass loss determinations by the same operator using the same equipment shall not be considered suspect unless they differ by more than 0.06 % (units of determination).
- b) **Reproducibility:** Mass loss determinations submitted by each of two laboratories shall not be considered suspect unless they differ by more than 0.2 % (units of determination).

Notes

1. Where the RTFO-treated sample is to be subsequently tested, an alternative procedure shall be followed. This allows the RTFO-treated material to be transferred into a test container. The test container shall be pre-weighed to the nearest 0.01 g and its mass recorded as M_4 . After pouring the treated sample into the container, cool both the RTFO bottle and the test container to room temperature. Weigh both the RTFO bottle (and residual treated sample) and the test container to the nearest 0.01 g. Record the mass of the RTFO bottle as M_5 and that of the test container as M_6 .
2. When treating binders with the roller method (Appendix A2) a wire hook (paper clip) can be used to support the roller over the open treatment bottle. This encourages more complete drainage of the binder back into the bottle.

The mass of the clip must be included in both the initial and final weighings to ensure all binder is accounted for.

3. Examples of comments on binder flow behaviour are:
 - (i) Sample remains fluid for the duration of the test.
 - (ii) Sample viscosity increased during the test, resulting in limited binder flow.
 - (iii) Sample failed to flow during test.

Example (i), above, is the only situation where the test gives a satisfactory measure of binder performance. If sample flow is restricted at any stage during the test, oxidation of the binder, or loss of volatiles, will be reduced and the test will not truly reflect the real effects of asphalt plant mixing and transportation.

APPENDIX A1 PRE-TREATMENT OF BITUMEN, MULTIGRADE AND POLYMER MODIFIED BINDERS (ROLLING THIN FILM OVEN (RTFO) TEST)

A1.1 SCOPE

This test method sets out the procedure for treating bitumen, multigrade and polymer modified binders using the modified RTFO procedure.

A1.2 REFERENCED DOCUMENTS

The following documents are referred to in this test method:

AUSTROADS

AG:PT/T101 Method of sampling polymer modified binders, polymers and crumb rubber

AG:PT/T102 Protocol for handling polymer modified binders in the laboratory

AS/NZS

AS2008 Residual bitumen for pavements, Appendix B - Sampling

2341.10 Determination of the effect of heat and air on a moving film of bitumen (rolling thin film oven (RTFO) test)

2341.13 Long-term exposure to heat and air

AAPA Australian Asphalt Pavement Association Code of Practice for the manufacture, making and laying of SBS modified asphalt

A1.3 APPARATUS

No additional apparatus beyond that that listed in AS/NZS 2341.10, is required.

A1.4 PROCEDURE

A1.4.1 General

PMBs are complex mixtures of polymers and a variety of petroleum products. If handled in accordance with the directions of the suppliers, there should be no significant risk. The hazard of burns with PMBs is greater than with standard bitumens, due to the (normally) higher handling temperatures. It is recommended that notices, describing the action to be taken in the event of bitumen or PMB burns, should be displayed in the laboratory in the areas where bitumen and PMBs are handled. A suitable warning could be as follows:

<p>WARNING: HOT BITUMEN & PMBs CAN CAUSE BURNS</p>

The following precautions should be taken when handling bitumen, or PMBs:

- f. Eye protection, such as safety glasses and/or face shields, shall be worn when handling hot bitumen or PMBs.
- g. Heat-resistant gloves, with close-fitting cuffs, and other suitable protective clothing, shall be worn when handling hot bitumen or PMBs.
- h. There shall be no smoking while handling hot bitumen or PMBs.
- i. While the material is still cold, loosen the lid of the sample container (invert the can and warm the lid, if necessary), or punch a hole in the lid.
- j. Examine the cold sample for the presence of water. If water is thought to be present, drain most of it out, or blow with clean compressed air to evaporate the free water.

A1.4.2 Sample preparation

PMB samples for testing shall be provided in accordance with AG:PT/T101 and AG:PT/T102. Bitumen and multigrade samples shall be provided in accordance with AS2008, Appendix B: Sampling.

A1.4.3 Oven calibration

The Oven treatment temperature (163°C unless specified otherwise) is established using the method given in AS/NZS 2341.13 Long-term exposure to heat and air. This establishes the 'in-bottle' temperature at 163°C with a floating Pt100 probe or suitable thermometer and is less dependant on the ovens design for good testing performance. A low cost approach to the calibration procedure is presented in Appendix B.

A1.4.4 Pre-treatment

Where specified, this procedure shall be followed as a precursor to the determination of asphalt grade binder characteristics.

- a) Sample establishment
 - i. For PMBs, establish a suitable sub-sample in accordance with MBT-02.
 - ii. Heat the sample in its container with a loosely fitted cover in an oven not exceeding the treatment temperature for the minimum time necessary to ensure that the sample is completely fluid. Manually stir the sample but avoid incorporating air bubbles.
 - iii. Select the required number of sample bottles to produce sufficient material for characterising tests which are to be performed on the residue.
 - iv. Pour 35 ± 0.5 g of the sample into each of the treatment bottles.
 - v. Allow the treatment bottles to cool to approximately room temperature (18 to 25°C).
- b) Treatment

- i. With the oven at the calibrated treatment temperature (Appendix B) for at least 2 hours, insert the treatment bottles into the carriage in a balanced arrangement and fill any remaining spaces with empty bottles.
 - ii. Leave the samples for 30 minutes without rotating the carriage or any air flowing.
 - iii. Start the rotation of the carriage and the air flow with the flow meter indicating 4 ± 0.5 L/min.
 - iv. Maintain the samples in the oven for 60 min (± 10 s), then switch off the carriage and airflow.
- c) Treated sample collection
- i. Leave the samples to settle in the stationary treatment bottles for 1 to 2 minutes.
 - ii. Taking out one bottle at a time, pour the contents from each bottle into a suitable container for testing. Drain each bottle until the treated material stops running freely (just dripping).
 - iii. Stir the material in the container briefly to ensure that the contents from all bottles are mixed to yield a representative sample.
 - iv. Testing on the treated samples should be completed within 24 hours.

A1.5 REPORT

The following information shall be reported:

- a) A comment on the sample behaviour during the test, in terms of its flow characteristics.
- b) If sample flow is restricted at any stage during the test, oxidation of the binder, or loss of volatiles, will be reduced and the test will not truly reflect the real effects of asphalt plant mixing and transportation.

A1.6 PRECISION

No inter-laboratory testing has been conducted for the range of PMBs currently available.

Since this test method is also a pre-treatment for subsequent performance testing, a measure of precision will be required when the procedure is partnered with the selected test method(s). This precision measure should be determined for each selected property.

APPENDIX A2 PRE-TREATMENT OF BITUMEN, MULTIGRADE AND POLYMER MODIFIED BINDERS (ROLLER DRIVEN THIN FILM OVEN (RDTFO) TEST)

A2.1 SCOPE

This test method sets out the procedure for treating bitumen, multigrade and polymer modified binders using the modified RTFO procedure.

A2.2 REFERENCED DOCUMENTS

The following documents are referred to in this test method:

AUSTROADS

AG:PT/T101 Method of sampling polymer modified binders, polymers and crumb rubber

AG:PT/T102 Protocol for handling polymer modified binders in the laboratory

AS/NZS

AS2008 Residual bitumen for pavements, Appendix B - SAMPLING

2341.10 Determination of the effect of heat and air on a moving film of bitumen (rolling thin film oven (RTFO) test)

2341.13 Long-term exposure to heat and air

AAPA

Australian Asphalt Pavement Association Code of Practice for the manufacture, making and laying of SBS modified asphalt

A2.3 APPARATUS

- a) Metal treatment bottles and rollers in accordance with the description provided in Appendix C.
- b) Oven carriage modifications in accordance with the description provided in Appendix D.

A2.4 PROCEDURES

A2.4.1 General

PMBs are complex mixtures of polymers and a variety of petroleum products. If handled in accordance with the directions of the suppliers, there should be no significant risk. The hazard of burns with PMBs is greater than with standard bitumens, due to the (normally) higher handling temperatures. It is recommended that notices, describing the action to be taken in the event of bitumen or PMB burns, should be displayed in the laboratory in the areas where bitumen and PMBs are handled. A suitable warning could be as follows:

WARNING: HOT BITUMEN & PMBs CAN CAUSE BURNS

The following precautions should be taken when handling bitumen, or PMBs:

- k. Eye protection, such as safety glasses and/or face shields, shall be worn when handling hot bitumen or PMBs.
- l. Heat-resistant gloves, with close-fitting cuffs, and other suitable protective clothing, shall be worn when handling hot bitumen or PMBs.
- m. There shall be no smoking while handling hot bitumen or PMBs.
- n. While the material is still cold, loosen the lid of the sample container (invert the can and warm the lid, if necessary), or punch a hole in the lid.
- o. Examine the cold sample for the presence of water. If water is thought to be present, drain most of it out, or blow with clean compressed air to evaporate the free water.

A2.4.2 Sample preparation

PMB samples for testing shall be provided in accordance with AG:PT/T101 and AG:PT/T102. Bitumen and multigrade samples shall be provided in accordance with AS2008, Appendix B: Sampling.

A2.4.3 Oven calibration

The RTF oven treatment temperature (163°C unless otherwise specified) is established using the method given in AS/NZS 2341.13 Long-term exposure to heat and air. This establishes the 'in-bottle' temperature at 163°C (see Note A2.1) with a floating Pt100 probe or suitable thermometer and is less dependant on the ovens design for good testing performance. A low cost approach to the calibration procedure is presented in Appendix B.

A2.4.4 Pre-treatment

Where specified, this procedure shall be followed as a precursor to the determination of asphalt grade binder characteristics.

- a) Sample establishment
 - i. For PMBs, establish a suitable sub-sample in accordance with AG:PT/T102.
 - ii. Heat the sample in its container with a loosely fitted cover in an oven not exceeding the treatment temperature for the minimum time necessary to ensure that the sample is completely fluid. Manually stir the sample but avoid incorporating air bubbles.
 - iii. Select the required number of sample bottles to produce sufficient material for characterising tests which are to be performed on the residue.
 - iv. Pour 50 ± 0.5 g of the sample into each of the treatment bottles.

- v. Allow the treatment bottles (with rollers) to cool to approximately room temperature (18 to 25°C).
- b) Treatment
- i. With the oven at the calibrated treatment temperature (Appendix B) for at least 2 hours, insert the treatment bottles and rollers into the carriage in a balanced arrangement and fill any remaining spaces with empty bottles.
 - ii. Leave the samples for 30 minutes without rotating the carriage or any air flowing.
 - iii. Start the rotation of the carriage and the air flow with the flow meter indicating 4 ± 0.5 L/min.
 - iv. Maintain the samples in the oven for 60 min (± 10 s), then switch off the carriage and airflow.
 - v. Remove the treatment bottles from the carriage and stand the samples in the oven.
- c) Treated sample collection
- i. Leave the samples to settle in the oven for 1 to 2 minutes. To aid sample collection, the lid can be removed and the roller suspended above the treated material.
 - ii. Taking out one bottle at a time, pour the contents from each bottle into a suitable container for testing. Drain each bottle until the treated material stops running freely (just dripping).
 - iii. Stir the material in the container briefly to ensure that the contents from all bottles are mixed to yield a representative sample.
 - iv. Testing on the treated samples should be completed within 24 hours.

A2.5 REPORT

The following information shall be reported:

- a) A comment on the sample behaviour during the test, in terms of its flow characteristics.
- b) If sample flow is restricted at any stage during the test, oxidation of the binder, or loss of volatiles will be reduced and the test will not truly reflect the real effects of asphalt plant mixing and transportation.

A2.6 PRECISION

No inter-laboratory testing has been conducted for the range of PMBs currently available.

Since this test method is also a pre-treatment for subsequent performance testing, a measure of precision will also be required when the procedure is partnered with the selected

performance related test method(s). This precision measure should be determined for each selected property.

Notes

- A2.1 The conventional glass treatment bottle is used in the calibration exercise.
- A2.2 Note : When treating binders with the roller method (Appendix A2) a wire hook (paper clip) can be used to support the roller over the open treatment bottle. This encourages complete drainage of the binder back into the bottle.

APPENDIX B RTFO OVEN TEMPERATURE CALIBRATION

B1 BACKGROUND

AS/NZS 2341.13 Long-term exposure to heat and air requires the establishment of an 'in-bottle' temperature of $100 \pm 0.3^\circ\text{C}$ with a floating Pt100 probe (or other appropriate thermometer). The precision required by the standard is within the capacity of the modern oven temperature controller and when used with an external calibration step against a calibrated reference thermometer will provide a low cost alternative method to that described in the standard. Currently several of the laboratories conducting this test use a more expensive Leeds and Northrup bridge for this purpose.

This RTF Oven calibration procedure relies on the stability of the Pt100 resistive temperature sensor to determine the internal treatment bottle temperature with the carriage in motion. This version of the method introduces several new initiatives to improve the precision of the calibration. Information on the thermal recovery characteristics of the oven can also be determined

B1.1 Pt100 Controller as a thermometer

A low cost option in resistance thermometry is described in WD 97-10.1 'Temperature measurement and control in the laboratory'. Experience with these units in situations where their calibration has been checked against a reference thermometer supports the view that their design provides an accurate long term measure of temperature to better than 0.3°C over a wide operating range.

B2 RTFO OVEN CALIBRATION

B2.1 SCOPE

This Appendix sets out a method for setting the oven temperature using a platinum resistance thermometer probe. The procedure uses the standard 163°C test as the basis for the description. Where other treatment temperatures are required, the calibration should be repeated.

B2.2 APPARATUS

The following apparatus is required:

- a) Platinum resistance thermometer probe. The construction of this probe and a suitable pivot point are shown in Fig. B1 and Fig. B2.

The probe shall consist of a straight stainless steel tube of 3 mm diameter and 0.25 mm wall thickness which shall be terminated at one end by a rounded brass cylinder (the tip), 9 mm diameter and 40 mm long.

The other end of the stainless tube shall be terminated in the pivot in a manner that is stable at the oven operating temperature (up to 180°C). The length of the probe from tip to pivot point shall be 280 mm.

A 100Ω platinum resistance temperature sensing element (Pt100), of approximately 3 mm diameter and 30 mm length, shall be fitted in the tip and connected to the pivot

by insulated wires (0.3 mm diameter) to form a four lead resistance thermometer. When used with a three terminal controller the leads can be reconfigured at the controller input.

Note: PTFE or other temperature resistant (180°C) material must be used for insulation of wires and cable.

The probe shall be calibrated at 163°C against a reference thermometer calibrated to an uncertainty of $\pm 0.1^\circ\text{C}$.

- b) Temperature controller Capable of measuring temperature with a Pt100 platinum resistance sensor with a resolution of 0.1°C and sufficient stability to repeat an annual calibration within $\pm 0.2^\circ\text{C}$.
- c) Reference thermometer Capable of calibrating the probe and controller system to an uncertainty of $\pm 0.1^\circ\text{C}$.
- d) Oven monitoring thermometer IP 16C or ASTM 16C.
- e) Resistance bridge (optional) Capable of measuring the resistance of a $100\ \Omega$ four lead resistance thermometer with a resolution of $0.01\ \Omega$ and limits of error of $\pm 0.01\ \Omega$

B2.3 PROCEDURE

The procedures shall be as follows:

- a) Pre-heat the oven to 163°C according to the monitoring thermometer or previous calibration if available.
- b) Place the probe and reference thermometer into a suitable calibration bath or block and determine the temperature on the controller corresponding to 163°C on the reference thermometer.
- c) Place 7 empty glass treatment bottles in the carriage. Place the tip of the platinum resistance probe in the remaining bottle containing 35 mL of oil (see Figure B2).. Secure the probe such that the tip of the probe is located inside the bottle about half way along. When the carriage is rotated, the probe should follow the bottle movement without fouling the jet.
- d) Lead the cable from the probe out of the oven and connect to the Temperature controller (or Resistance bridge). Ensure that sufficient cable length remains within the oven to avoid stress on the probe-cable interface during carriage rotation.
- e) Insert the oven monitoring thermometer securely into its service position. Commence air flow at $4 \pm 0.5\ \text{L/min}$ and allow the oven to stabilise at a set point of 163°C .
- f) Reset the oven temperature as necessary until readings on the Temperature controller (connected to the probe) or the Resistance bridge indicate that the temperature in the bottle is 163°C . Take sufficient readings over the necessary period of time and record the temperature on the monitoring thermometer and oven controller. This reading becomes the oven calibration.

- g) After the calibration, remove the platinum resistance thermometer probe and pivot assembly from the oven. Ensure that the air jet is aligned with the opening in the treatment bottle. Application of the calibration probe can disturb its position.

Notes

1. Most recently manufactured treatment ovens use Pt100 based temperature controllers. The set point on the oven controller can be used in place of the monitoring thermometer.
2. The oven should reach a stable state after 2 hours of operation. Calibration should be undertaken with the laboratory at normal operating temperature. Ideally, the temperature will be in the range 18 - 24°C and the oven will not be exposed to direct heat from the sun.

B3 RTFO OVEN TEMPERATURE CALIBRATION (THERMOMETER METHOD)

An alternative oven calibration procedure using a thermometer in the treatment bottle is described in AS/NZS 2341.13 Appendix B. A calibrated thermometer (IP32C for 100°C) is secured across the face of the carriage with the bulb passing through a hole in a modified treatment bottle. The thermometer required for a higher temperature calibration must be a total immersion type of length suited for the placement shown in Fig B3. Details of this method are provided in AS/NZS 2341.13.

B4 RTFO OVEN TEMPERATURE RECOVERY ASSESSMENT

Using the same apparatus and procedure described in section B2, the temperature recovery characteristics of the oven can be assessed. Although this is not a routine calibration exercise, users should validate the characteristics of their oven to confirm its ability to attain the test temperature from a cold (sample and bottle) start. This should be assessed for the 35 gram glass bottle standard RTFO system with all bottles carrying 35 ± 1 g of oil. No additional testing is required for the alternative metal bottles.

The fully loaded oven should achieve greater than 160°C within the 30 minutes recovery period for a 163°C calibrated treatment temperature.

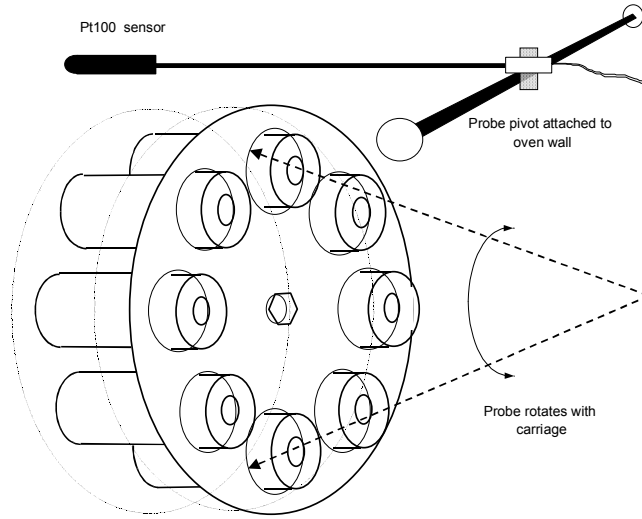

Figure B1. Probe Construction and Oven Assembly

Note: Greater detail is provided in AS/NZS 2341.13 Appendix A. The use of the oil bath during calibration allows the actual dimensions to be flexible. The probe as described in AS.NZS 2341.13 is recommended.

An improved approach uses a 35 mL oil bath to improve thermal transfer to the tip of the probe. AS/New Zealand 2341.13 relies on air to achieve the heat transfer

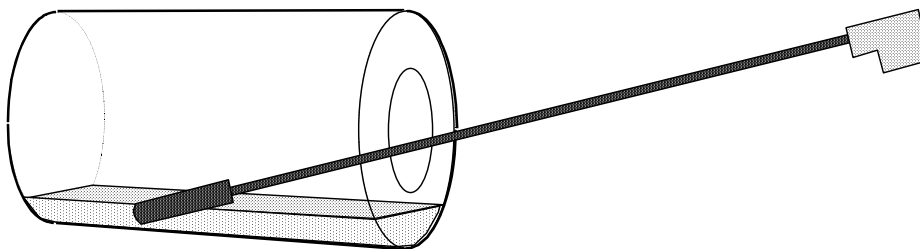

Figure B2. Probe and oil bath

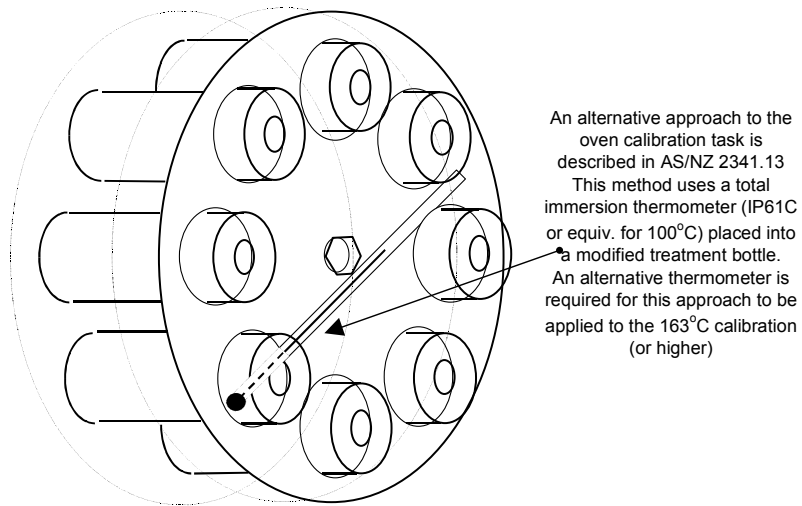

Figure B3. Calibration thermometer (alternative approach)

APPENDIX C RTFO BOTTLE MODIFICATION

The following bottle description applies to the RTFO method described in Appendix A2.

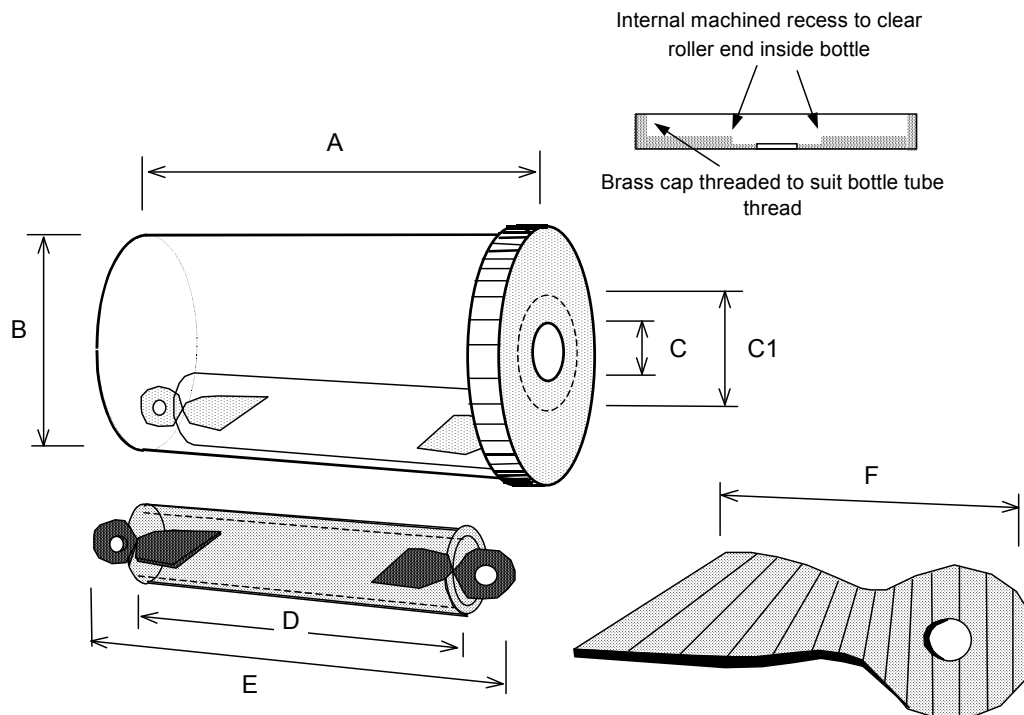

Figure C1. Metal bottle and roller assembly

Table C1 Dimensions for apparatus described by Fig. C1

Label	Item	Dimension
A	Brass tube (length), closed at base with 1.6 mm brass plate, external thread to match cap at top.	140 ± 1 mm
B	Nominal (2.5 inch ϕ) with 1.6 mm wall	63 ± 1 mm
C	Air hole in screw cap (diameter)	12 ± 0.5 mm
C1	Internal recess approximately 3 mm deep	30 ± 1 mm
D	20 mm ϕ standard brass threaded tube	120 ± 1 mm
E	Length of roller including ends	$138 + 0, -1$ mm
F	Length of 1.6 mm brass end pieces with 90 degree left hand twist viewed from end of roller	40 ± 2 mm

APPENDIX D CARRIAGE MODIFICATION

When using the heavier brass treatment bottles and rollers, a modification to the bottle retaining clips may be required to reduce the tendency for the treatment bottles to work out of the carriage.

Fig. D1 describes a rearrangement of the bottle retaining clips.

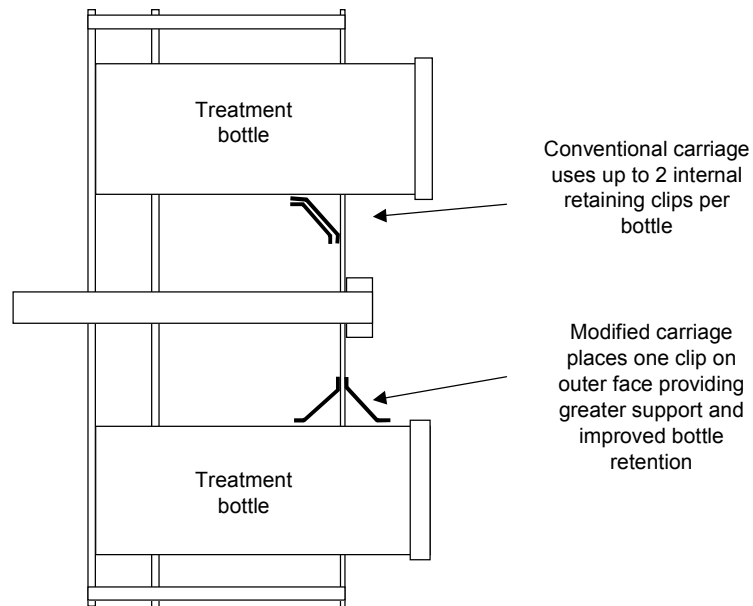

Figure D1. RTFO bottle retaining clip modification

AMENDMENT RECORD

Amendment No.	Clauses amended	Action	Date
1	Original draft	New	November 2000
2	Commentary Page	New	March 2006
	Footer and header	Format	
	Applied revised test method number	Format	
	Applied new styles	Format	

Key

Format	Change in format
Substitution	Old clause removed and replaced with new clause
New	Insertion of new clause
Removed	Old clauses removed